



Oro tiekimo agregatai

Air handling units

Lüftungsgeräte

Приточные агрегаты



- Mažas triukšmo lygis
- Reguliuojamo greičio ventilatorius (įtampos keitimas)
- Elektrinis arba vandeninis šildytuvas
- Lengvai nuimamas dangtis patikrinimui
- Filtrų dėžė su EU5 arba EU3 klasės filtru

Oro tiekimo agregatas skirtas oro padavimui į patalpas. Jis susideda iš išcentrinio ventilatoriaus, kurio greitis gali būti valdomas reguliatoriumi, oro šildytuvo ir kišeninio filtro. Agregatams, kurių šildymo galingumas iki 3,2 kW (~1f) arba iki 6 kW (~2f), gali būti naudojami elektrinio šildymo reguliatoriai EKR 6. Visi šie elementai sumontuoti izoliuotame korpuse. Izoliacijos storis 50 mm. Korpusas pagamintas iš cinkuotos skardos su lengvai nuimamu dangčiu. Dangtis tvirtinamas keturiais lengvai atsegamais lankstais.



- Niedriges Geräuschniveau
- Ventilator mit Geschwindigkeitsregelung (Spannungsänderung)
- Elektrische oder Wasser-Erwärmungseinrichtung
- Leicht abnehmbarer Deckel für Wartung
- Filterkasten mit dem Filter der EU5 oder EU3-Klasse

Das Zuluft-Aggregat ist für Luftlieferung in Räumlichkeiten bestimmt. Es besteht aus einem Zentrifugalventilator, dessen Geschwindigkeit mithilfe eines Reglers gesteuert werden kann, einer Lufterwärmungseinrichtung und einem Taschenfilter. Für Aggregate mit einer Erwärmungsleistung bis 3,2 kW (~1f) oder bis 6 kW (~2f) können Regler der elektrischen Erwärmung EKR 6 verwendet werden. Alle diese Elemente sind im isolierten Gehäuse montiert. Isolationsdicke 50 mm. Das Gehäuse ist aus verzinktem Blech mit leicht abnehmbarem Deckel hergestellt. Der Deckel wird mit vier leicht aufknöpfbaren Scharnieren befestigt.



- Low noise level
- Adjustable voltage fan control
- Electrical or water heater
- Easily removable inspection cover
- Filter box with pocket filter EU5 class
- Possibility to install in ceiling

Air supply units for ventilation systems. Not designed for functioning in explosive – inclined areas. The unit is designed for the air supply into premises. Heaters with power capacity are: up to 3,2kW (~1f) or 6kW (~2f) and from 6kW (~3f).



- Низкий уровень шума
- Вентилятор с регулированием скорости (изменение напряжения)
- Электрический или водяной нагреватель
- Легко снимаемая крышка для проверки.
- Кассета фильтров с фильтром класса EU5 или EU3.

Агрегат подачи воздуха предназначен для подачи воздуха в помещения. Он состоит из эксцентрического вентилятора, скорость которого изменяется регулятором, а также нагревателя воздуха и карманного фильтра. Все эти элементы установлены в изолированном корпусе. Толщина изоляции 50 мм. Корпус изготовлен из оцинкованной жести с легко снимаемой крышкой. Крышка крепится легко отстёгивающимися шарнирами. Для агрегатов, у которых тепловая мощность до 3,2 kW (~1f) или 6 kW (~2f), могут быть использованы электрические регуляторы тепла EKR 6.

Accessories



AP
p. 185



RSK
SAT
p. 167-168



SKM
p. 162



SSK
p. 165



SSP
p. 159



AKS
p. 160

VEKA 400 - 2000

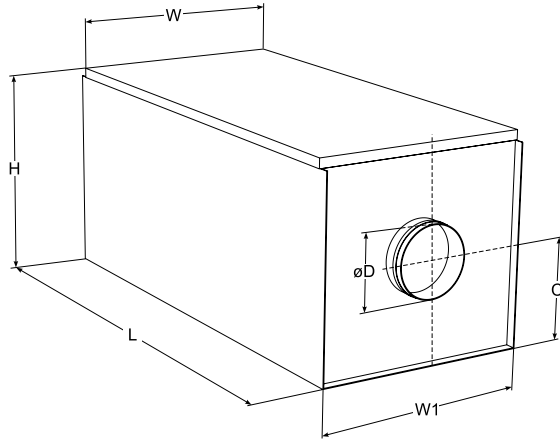

VEKA 3000 - 4000

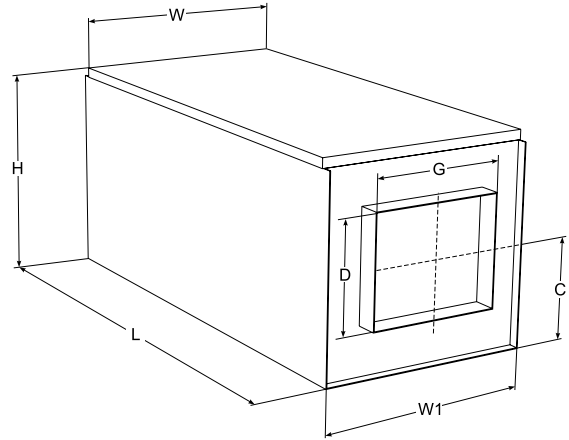

Type	Dimensions [mm]					
	W, mm	W1, mm	C, mm	L, mm	H, mm	ØD, mm
VEKA 400	434	430	125	900	250	125
VEKA 700/2,4 - 9,0	464	460	216	1000	400	160
VEKA 700/12,0	464	460	216	1130	400	160
VEKA 850/2,0 - 3,0	464	460	216	1000	400	200
VEKA 850/5,0 - 9,0	464	460	216	1100	400	200
VEKA 850/12,0	464	460	216	1230	400	200
VEKA 1000/2,4	614	610	198	1150	400	250
VEKA 1000/5,0	614	610	198	1300	400	250
VEKA 1000/9,0 - 12,0	614	610	198	1400	400	250
VEKA W-1000/13,6	614	610	198	1400	400	250
VEKA 2000	704	700	256	1500	500	315

Type	Dimensions [mm]						
	W, mm	W1, mm	C, mm	L, mm	H, mm	D, mm	G, mm
VEKA 3000	824	820	239	1500	500	300	500
VEKA 4000	924	920	300	1700	600	400	600

Accessories



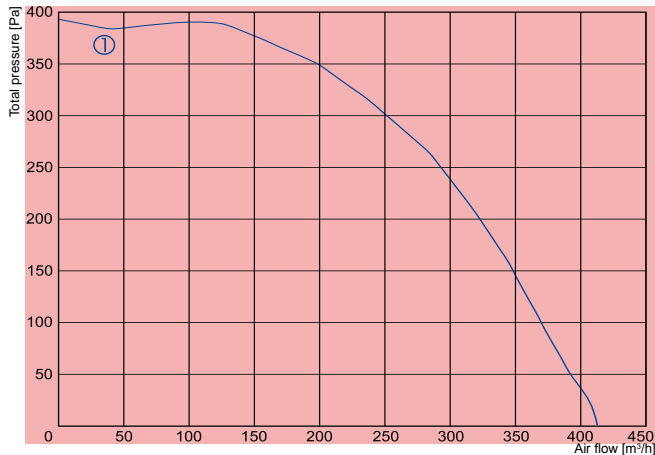

- ① VEKA 400/1,2-L1
- ① VEKA 400/2,0-L1
- ① VEKA 400/5,0-L1

		400/1,2-L1	400/2,0-L1	400/5,0-L1
Heater	-phase/voltage [50Hz/VAC]	~1, 230	~1, 230	~2, 400
	-power consumption [kW]	1,2	2,0	5,0
	-min. air speed [m/s]	1,5	1,5	1,5
Fan	-phase/voltage [50Hz/VAC]	~1, 230	~1, 230	~1, 230
	-current [A]	0,80	0,80	0,80
	-speed [min ⁻¹]	2120	2120	2120
	-power consumption [kW]	0,19	0,19	0,19
	-max. airflow [m³/h]	414	414	414
	-motor protection class	IP-44	IP-44	IP-44
	Terminal box protection class	IP-54	IP-54	IP-54
	Filter class	EU5	EU5	EU5
	Total sound pressure level at 1 m [dBA]	41	41	41
	Wiring diagram	No. 1	No. 1	No. 2

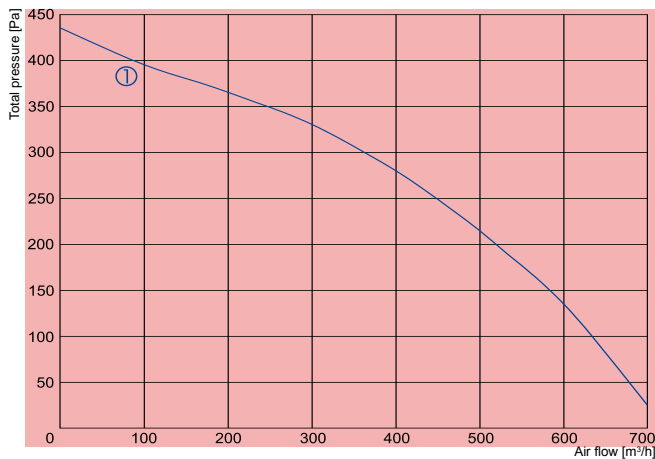

- ① VEKA 700/2,4-L1
- ① VEKA 700/5,0-L1
- ① VEKA 700/9,0-L1
- ① VEKA 700/12,0-L1

		700/2,4-L1	700/5,0-L1	700/9,0-L1	700/12,0-L1
Heater	-phase/voltage [50Hz/VAC]	~1, 230	~2, 400	~3, 400	~3, 400
	-power consumption [kW]	2,4	5,0	9,0	12,0
	-min. air speed [m/s]	1,5	1,5	1,5	1,5
Fan	-phase/voltage [50Hz/VAC]	~1, 230	~1, 230	~1, 230	~1, 230
	-current [A]	1,7	1,7	1,7	1,7
	-speed [min ⁻¹]	2200	2200	2200	2200
	-power consumption [kW]	0,23	0,23	0,23	0,23
	-max. airflow [m³/h]	700	700	700	700
	-motor protection class	IP-44	IP-44	IP-44	IP-44
	Terminal box protection class	IP-54	IP-54	IP-54	IP-54
	Filter class	EU5	EU5	EU5	EU5
	Total sound pressure level at 1 m [dBA]	45	45	45	45
	Wiring diagram	No. 1	No. 2	No. 3	No. 3

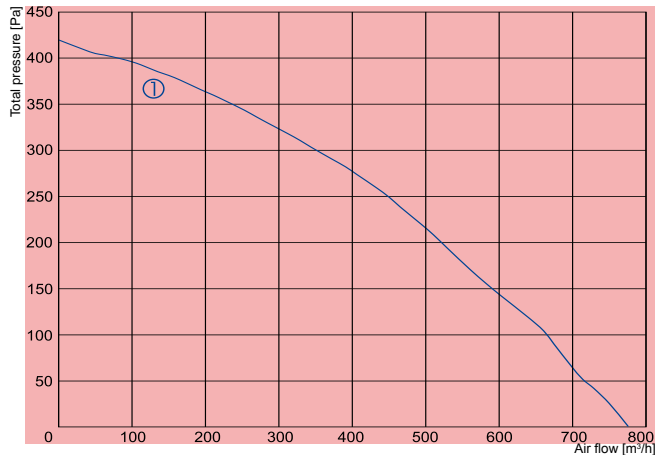

- ① — VEKA 850/2,0-L1
- ① — VEKA 850/3,0-L1
- ① — VEKA 850/5,0-L1
- ① — VEKA 850/6,0-L1
- ① — VEKA 850/9,0-L1
- ① — VEKA 850/12,0-L1

		850/2,0-L1	850/3,0-L1	850/5,0-L1	850/6,0-L1	850/9,0-L1	850/12,0-L1
Heater	-phase/voltage [50Hz/VAC]	~1, 230	~1, 230	~2, 400	~2, 400	~3, 400	~3, 400
	-power consumption [kW]	2	3	5	6	9	12
	-min. air speed [m/s]	1,5	1,5	1,5	1,5	1,5	1,5
Fan	-phase/voltage [50Hz/VAC]	~1, 230	~1, 230	~1, 230	~1, 230	~1, 230	~1, 230
	-current [A]	1,18	1,18	1,18	1,18	1,18	1,18
	-speed [min ⁻¹]	1190	1190	1190	1190	1190	1190
	-power consumption [kW]	0,28	0,28	0,28	0,28	0,28	0,28
	-max. airflow [m ³ /h]	775	775	775	775	775	775
	-motor protection class	IP-44	IP-44	IP-44	IP-44	IP-44	IP-44
Terminal box protection class		IP-54	IP-54	IP-54	IP-54	IP-54	IP-54
Filter class		EU5	EU5	EU5	EU5	EU5	EU5
Total sound pressure level at 1 m	[dBA]	46	46	46	46	46	46
Wiring diagram		No. 1	No. 1	No. 2	No. 2	No. 3	No. 3

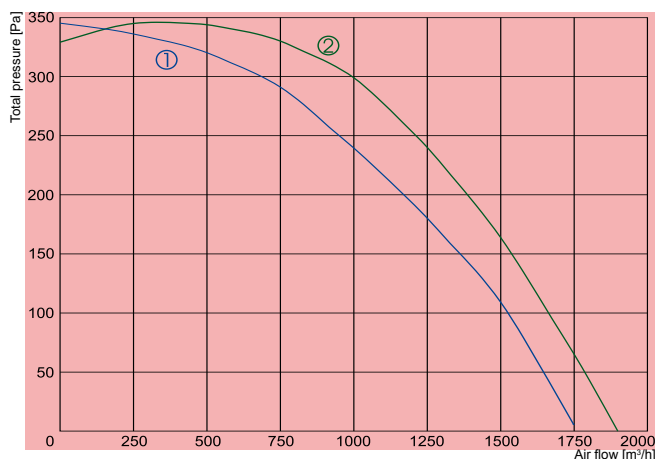

- ① — VEKA1000/2,4-L1
- ② — VEKA1000/2,4-L3
- ① — VEKA1000/5,0-L1
- ② — VEKA1000/5,0-L3

		1000/2,4-L1	1000/2,4-L3	1000/5,0-L1	1000/5,0-L3
Heater	-phase/voltage [50Hz/VAC]	~1, 230	~1, 230	~2, 400	~2, 400
	-power consumption [kW]	2,4	2,4	5	5
	-min. air speed [m/s]	1,5	1,5	1,5	1,5
Fan	-phase/voltage [50Hz/VAC]	~1, 230	~3, 400	~1, 230	~3, 400
	-current [A]	3,0	1,9	3,0	1,9
	-speed [min ⁻¹]	1190	1380	1190	1380
	-power consumption [kW]	0,69	0,93	0,69	0,93
	-max. airflow [m ³ /h]	1750	1900	1750	1900
	-motor protection class		IP-54	IP-54	IP-54
Terminal box protection class		IP-54	IP-54	IP-54	IP-54
Filter class		EU5	EU5	EU5	EU5
Total sound pressure level at 1 m	[dBA]	52	52	52	52
Wiring diagram		No. 4	No. 5	No. 6	No. 7

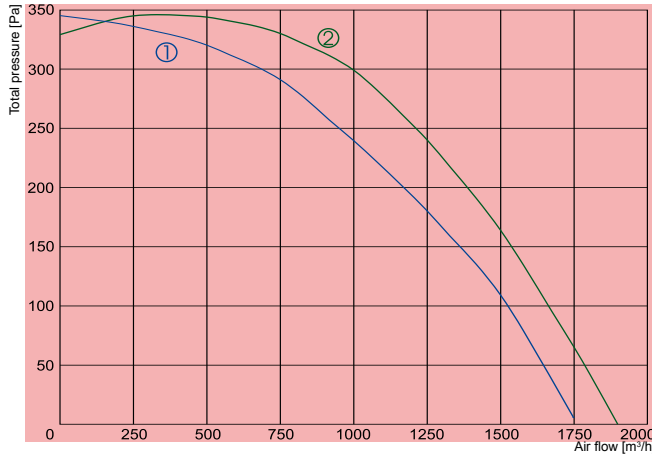

- ① — VEKA1000/9,0-L1
- ② — VEKA1000/9,0-L3
- ① — VEKA1000/12,0-L1
- ② — VEKA1000/12,0-L3

		1000/9,0-L1	1000/9,0-L3	1000/12,0-L1	1000/12,0-L3
Heater	-phase/voltage [50Hz/VAC]	~3, 400	~3, 400	~3, 400	~3, 400
	-power consumption [kW]	9	9	12	12
	-min. air speed [m/s]	1,5	1,5	1,5	1,5
Fan	-phase/voltage [50Hz/VAC]	~1, 230	~3, 400	~1, 230	~3, 400
	-current [A]	3,0	1,9	3,0	1,9
	-speed [min ⁻¹]	1190	1380	1190	1380
	-power consumption [kW]	0,69	0,93	0,69	0,93
	-max. airflow [m³/h]	1750	1900	1750	1900
-motor protection class		IP-54	IP-54	IP-54	IP-54
Terminal box protection class		IP-54	IP-54	IP-54	IP-54
Filter class		EU5	EU5	EU5	EU5
Total sound pressure level at 1 m [dBA]		52	52	52	52
Wiring diagram		No. 8	No. 9	No. 12	No. 13

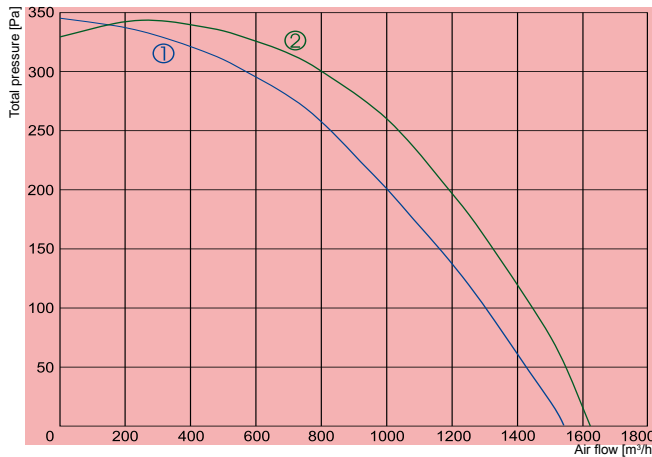

- ① — VEKA W-1000/13,6-L1
- ② — VEKA W-1000/13,6-L3

		W-1000/13,6-L1	W-1000/13,6-L3
Water heater	-power [kW]	13,6	13,6
	-water temp. T _{in} /T _{out} [°C]	+80/+60	+80/+60
	-water flow rate [l/s]	0,16	0,16
	-water pressure drop [kPa]	14	14
Fan	-phase/voltage [50Hz/VAC]	~1, 230	~3, 400
	-current [A]	3,0	1,9
	-speed [min ⁻¹]	1190	1380
	-power consumption [kW]	0,69	0,93
	-max. airflow [m³/h]	1540	1620
-motor protection class		IP-54	IP-54
Terminal box protection class		IP-54	IP-54
Filter class		EU5	EU5
Total sound pressure level at 1 m [dBA]		52	52
Wiring diagram		No. 14	No. 15

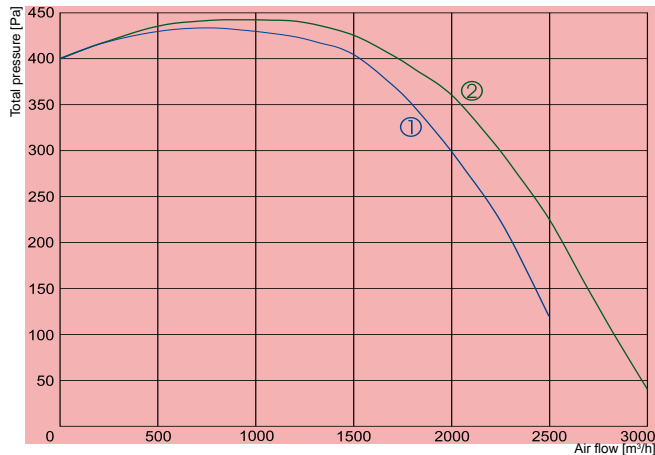

- ① — VEKA 2000/6,0-L1
- ② — VEKA 2000/6,0-L3
- ① — VEKA 2000/15,0-L1
- ② — VEKA 2000/15,0-L3
- ① — VEKA 2000/21,0-L1
- ② — VEKA 2000/21,0-L3

		2000/6,0-L1	2000/6,0-L3	2000/15,0-L1	2000/15,0-L3	2000/21,0-L1	2000/21,0-L3
Heater	-phase/voltage [50Hz/VAC]	~2,400	~2,400	~3,400	~3,400	~3,400	~3,400
	-power consumption [kW]	6	6	15	15	21	21
	-min. air speed [m/s]	1,5	1,5	1,5	1,5	1,5	1,5
Fan	-phase/voltage [50Hz/VAC]	~1,230	~3,400	~1,230	~3,400	~1,230	~3,400
	-current [A]	5,1	2,6	5,1	2,6	5,1	2,6
	-speed [min ⁻¹]	1210	1310	1210	1310	1210	1310
	-power consumption [kW]	1,15	1,50	1,15	1,50	1,15	1,50
	-max. airflow [m³/h]	2500	3000	2500	3000	2500	3000
	-motor protection class	IP-54	IP-54	IP-54	IP-54	IP-54	IP-54
Terminal box protection class		IP-54	IP-54	IP-54	IP-54	IP-54	IP-54
Filter class		EU5	EU5	EU5	EU5	EU5	EU5
Total sound pressure level at 1 m	[dBA]	54	54	54	54	54	54
Wiring diagram		No. 10	No. 11	No. 12	No. 13	No. 12	No. 13

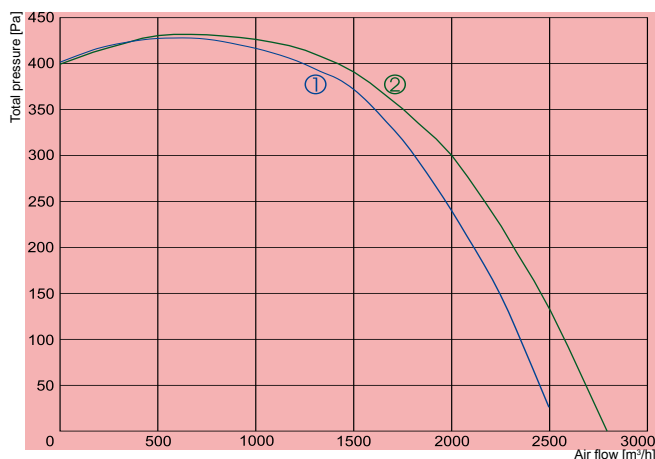

- ① — VEKA W-2000/27,2-L1
- ② — VEKA W-2000/27,2-L3

		W-2000/27,2-L1	W-2000/27,2-L3
Water heater	-power [kW]		27,2
	-water temp. T _{in} /T _{out} [°C]		+80/+60
	-water flow rate [l/s]		0,34
	-water pressure drop [kPa]		15
Fan	-phase/voltage [50Hz/VAC]	~1,230	~3,400
	-current [A]	5,1	2,6
	-speed [min ⁻¹]	1210	1310
	-power consumption [kW]	1,15	1,50
	-max. airflow [m³/h]	2500	2790
	-motor protection class	IP-54	IP-54
Terminal box protection class		IP-54	IP-54
Filter class		EU5	EU5
Total sound pressure level at 1 m	[dBA]	54	54
Wiring diagram		No. 14	No. 15

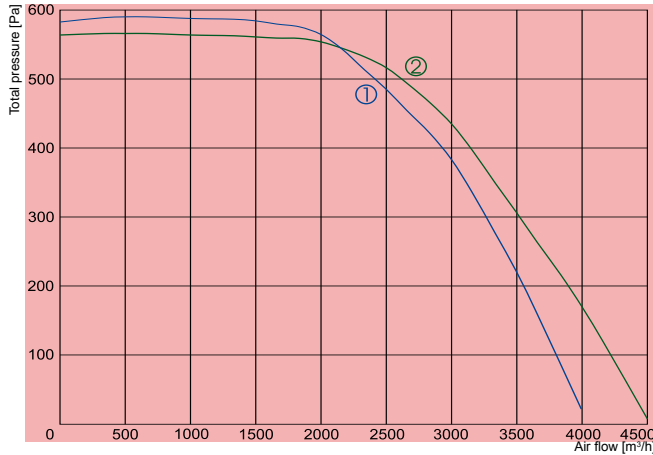

- ① — VEKA 3000/15,0-L1
- ② — VEKA 3000/15,0-L3
- ① — VEKA 3000/21,0-L1
- ② — VEKA 3000/21,0-L3

		3000/15,0-L1	3000/15,0-L3	3000/21,0-L1	3000/21,0-L3
Heater	-phase/voltage [50Hz/VAC]	~3, 400	~3, 400	~3, 400	~3, 400
	-power consumption [kW]	15	15	21	21
	-min. air speed [m/s]	1,5	1,5	1,5	1,5
Fan	-phase/voltage [50Hz/VAC]	~1, 230	~3, 400	~1, 230	~3, 400
	-current [A]	11,0	4,1	11,0	4,1
	-speed [min ⁻¹]	1340	1300	1340	1300
	-power consumption [kW]	2,5	2,5	2,5	2,5
	-max. airflow [m³/h]	4000	4500	4000	4500
-motor protection class		IP 54	IP 54	IP 54	IP 54
Terminal box protection class		IP 54	IP 54	IP 54	IP 54
Filter class		EU5	EU5	EU5	EU5
Total sound pressure level at 1 m [dBA]		56	56	56	56
Wiring diagram		No 12	No. 13	No. 12	No. 13

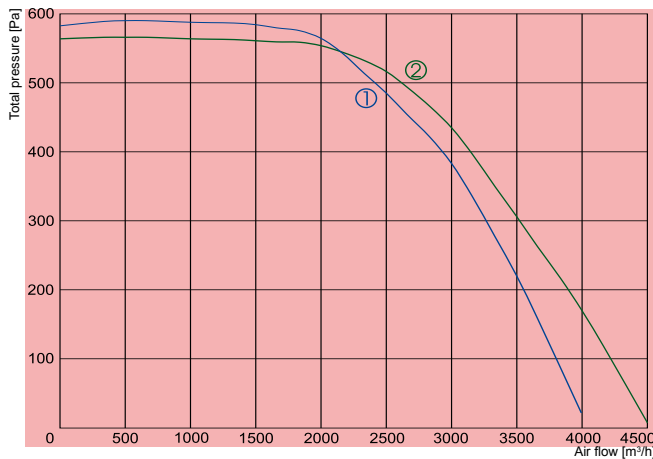

- ① — VEKA 3000/30,0-L1
- ② — VEKA 3000/30,0-L3
- ① — VEKA 3000/39,0-L1
- ② — VEKA 3000/39,0-L3

		3000/30,0-L1	3000/30,0-L3	3000/39,0-L1	3000/39,0-L3
Heater	-phase/voltage [50Hz/VAC]	~3, 400	~3, 400	~3, 400	~3, 400
	-power consumption [kW]	30	30	39	39
	-min. air speed [m/s]	1,5	1,5	1,5	1,5
Fan	-phase/voltage [50Hz/VAC]	~1, 230	~3, 400	~1, 230	~3, 400
	-current [A]	11,0	4,1	11,0	4,1
	-speed [min ⁻¹]	1340	1300	1340	1300
	-power consumption [kW]	2,5	2,5	2,5	2,5
	-max. airflow [m³/h]	4000	4500	4000	4500
-motor protection class		IP 54	IP 54	IP 54	IP 54
Terminal box protection class		IP 54	IP 54	IP 54	IP 54
Filter class		EU5	EU5	EU5	EU5
Total sound pressure level at 1 m [dBA]		56	56	56	56
Wiring diagram		No. 12	No. 13	No. 12	No. 13

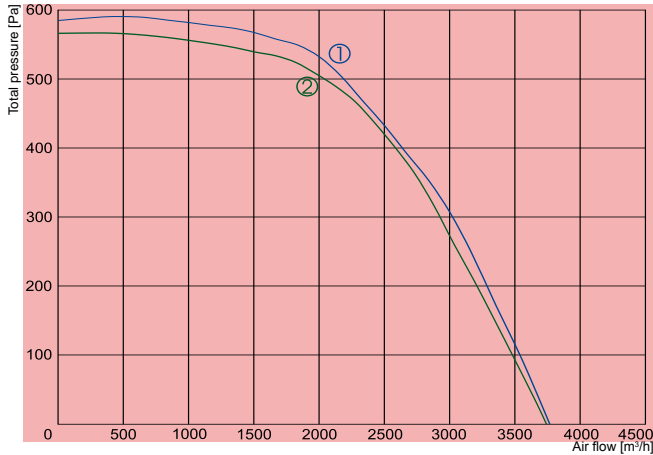

- ① VEKA W-3000/40,8-L1
- ② VEKA W-3000/40,8-L3

		W-3000/40,8-L1	W-3000/40,8-L3
Water heater	-power [kW]	40,8	40,8
	-water temp. T_{in}/T_{out} [°C]	+80/+60	+80/+60
	-water flow rate [l/s]	0,48	0,48
Fan	-water pressure drop [kPa]	12	12
	-phase/voltage [50Hz/VAC]	~1, 230	~3, 400
	-current [A]	11	4,10
	-speed [min ⁻¹]	1340	1300
	-power consumption [kW]	2,5	2,5
	-max. airflow [m³/h]	3770	3740
	-motor protection class	IP 54	IP 54
Terminal box protection class	IP 54	IP 54	
Filter class	EU5	EU5	
Total sound pressure level at 1 m [dBA]	56	56	
Wiring diagram		No. 14	No. 15

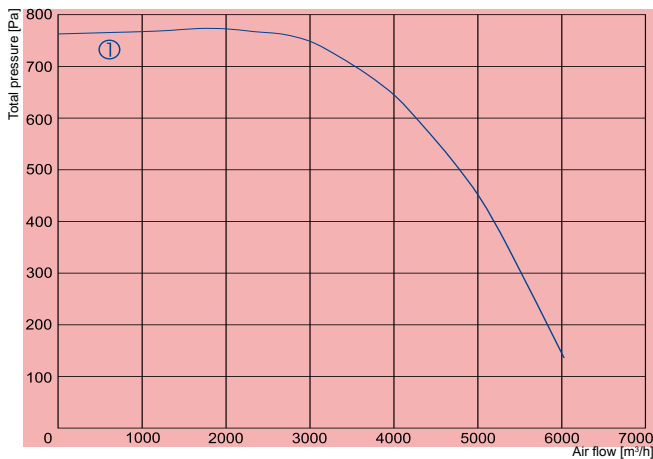

- ① VEKA 4000/21,0-L3
- ① VEKA 4000/27,0-L3
- ① VEKA 4000/39,0-L3
- ① VEKA 4000/54,0-L3

		4000/21,0-L3	4000/27,0-L3	4000/39,0-L3	4000/54,0-L3
Heater	-phase/voltage [50Hz/VAC]	~3, 400	~3, 400	~3, 400	~3, 400
	-power consumption [kW]	21	27	39	54
	-min. air speed [m/s]	1,5	1,5	1,5	1,5
Fan	-phase/voltage [50Hz/VAC]	~3, 400	~3, 400	~3, 400	~3, 400
	-current [A]	6,0	6,0	6,0	6,0
	-speed [min ⁻¹]	1320	1320	1320	1320
	-power consumption [kW]	3,7	3,7	3,7	3,7
	-max. airflow [m³/h]	6020	6020	6020	6020
	-motor protection class	IP 54	IP 54	IP 54	IP 54
	Terminal box protection class	IP 54	IP 54	IP 54	IP 54
Filter class	EU5	EU5	EU5	EU5	
Total sound pressure level at 1 m [dBA]	58	58	58	58	
Wiring diagram		No. 13	No. 13	No. 13	No. 13

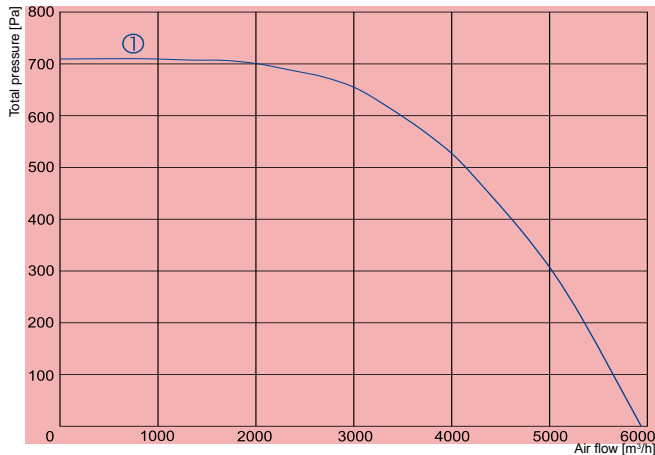

① **VEKA W-4000/54,0-L3**

Air handling units

W-4000/54,0-L3

Water heater	-power	[kW]	54
	-water temp. T_{in}/T_{out}	[°C]	+80/+60
	-water flow rate	[l/s]	0,71
	-water pressure drop	[kPa]	16
Fan	-phase/voltage	[50Hz/VAC]	~3, 400
	-current	[A]	6,0
	-speed	[min ⁻¹]	1320
	-power consumption	[kW]	3,7
	-max. airflow	[m³/h]	5940
	-motor protection class		IP-54
	Terminal box protection class		IP-54
	Filter class		EU5
	Total sound pressure level at 1 m	[dBA]	58
	Wiring diagram		No. 15

Wiring diagram No. 1

- C** -Centrifugal fan
- D** -Electrical heater

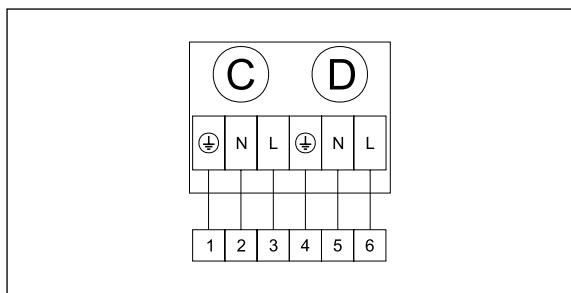

Wiring diagram No. 2

- C** -Centrifugal fan
- D** -Electrical heater

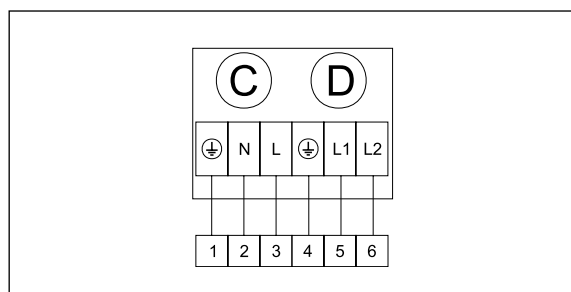

Wiring diagram No. 3

- C** -Centrifugal fan
- D** -Electrical heater

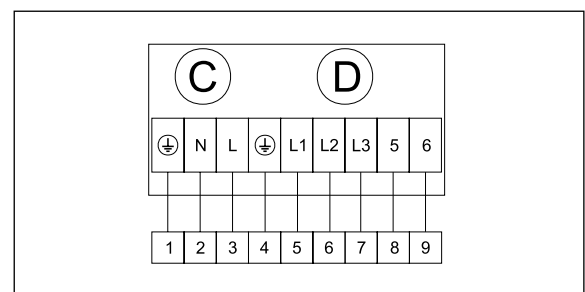

Wiring diagram No. 4

- C -Centrifugal fan
- D -Electrical heater

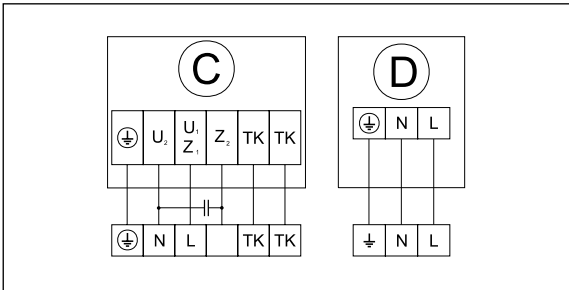

Wiring diagram No. 5

- C -Centrifugal fan
- D -Electrical heater

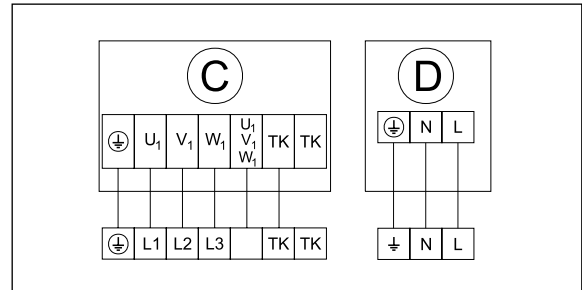

Wiring diagram No. 6

- C -Centrifugal fan
- D -Electrical heater

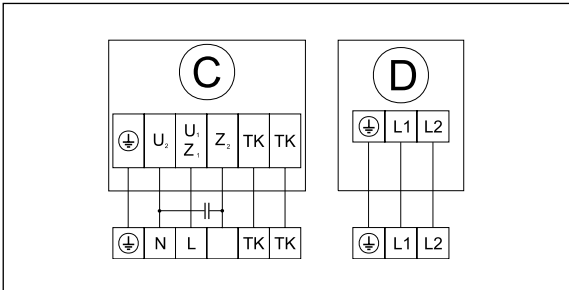

Wiring diagram No. 7

- C -Centrifugal fan
- D -Electrical heater

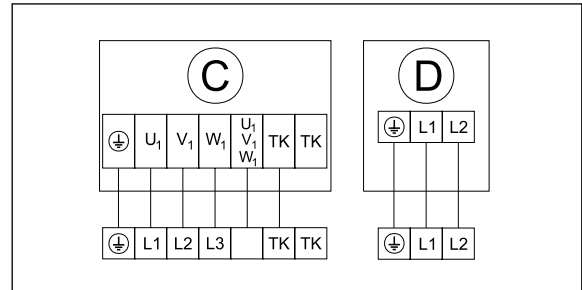

Wiring diagram No. 8

- C -Centrifugal fan
- D -Electrical heater

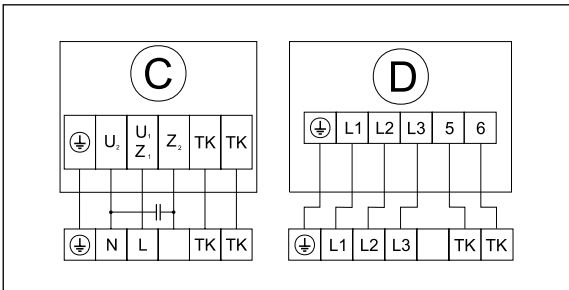

Wiring diagram No. 9

- C -Centrifugal fan
- D -Electrical heater

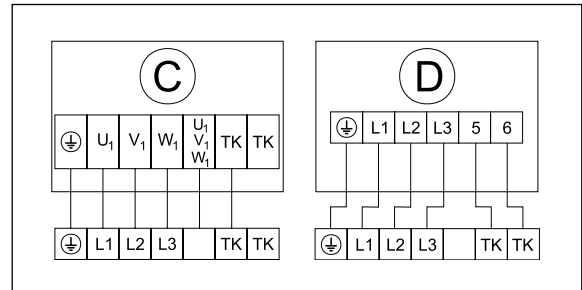

Wiring diagram No. 10

- A -Overheat protection with manual reset 120°C
- B -Overheat protection with automatical reset 60°C
- C -Centrifugal fan
- D -Electrical heater

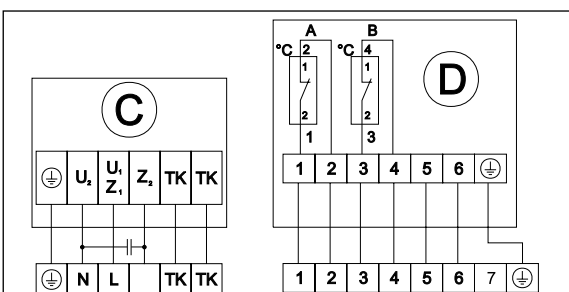

Wiring diagram No. 11

- A -Overheat protection with manual reset 120°C
- B -Overheat protection with automatical reset 60°C
- C -Centrifugal fan
- D -Electrical heater

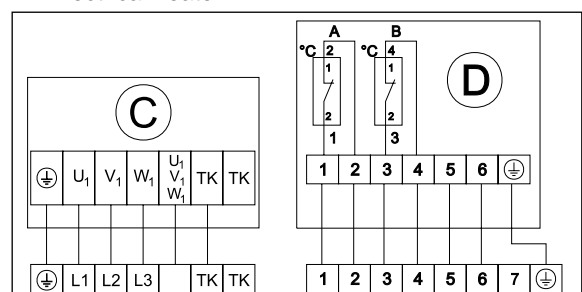

Wiring diagram No. 12

- A -Overheat protection with manual reset 120°C
- B -Overheat protection with automatical reset 60°C
- C -Centrifugal fan
- D -Electrical heater

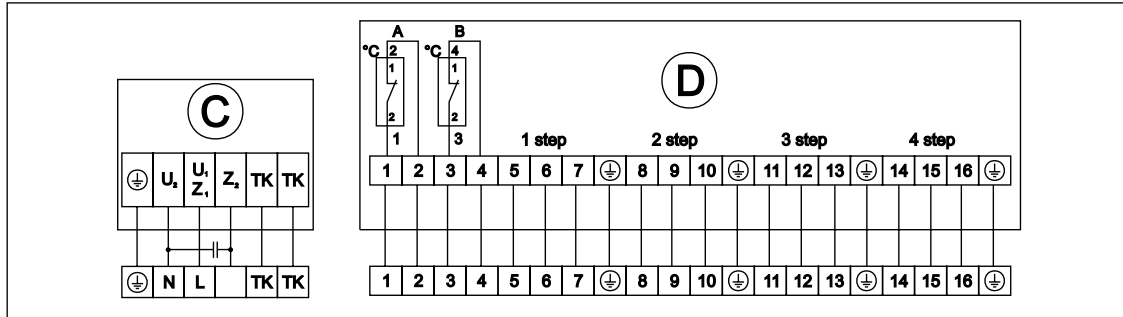

Wiring diagram No. 13

- A -Overheat protection with manual reset 120°C
- B -Overheat protection with automatical reset 60°C
- C -Centrifugal fan
- D -Electrical heater

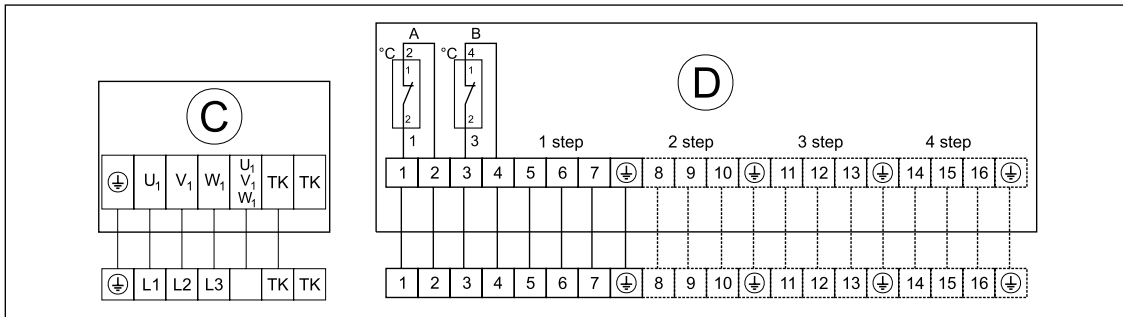

Wiring diagram No. 14

- C -Centrifugal fan

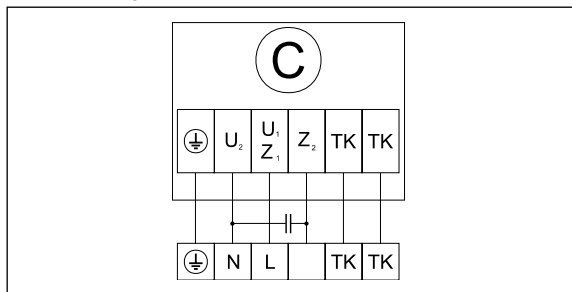

Wiring diagram No. 15

- C -Centrifugal fan

