



Akustiniai kanaliniai ventiliatoriai

Acoustically insulated fans

Isolierte Rohrventilatoren

Канальные акустические вентиляторы



Kanaliniai, akustiniai ventiliatoriai, pasižymi žemu triukšmo lygiu įsiurbimo kanale ir į aplinką. Apžiūros dangtis lengvai atidaromas ir prie korpuso tvirtinamas lankstais, todėl ventiliatorių lengva prižiūrėti bei valyti. Nenaudojami užteršto oro, agresyvių, sprogių dujų transportavimui.

Sparnuotė: į priekį lenktais sparneliais, cinkuoto plieno.

Variklis: išorinis rotorius, ilgai tarnaujantys nereikalaujantys priežiūros guoliai.

Korpusas: iš cinkuotos skardos, iš alucinko skardos.

Garso izoliacija: akmens vatos, akmens vatos su sustiprintu paviršiumi, 50mm – 30mm storio, nedegi.



Kanal-, Akustik-Ventilatoren, die sich durch ein niedriges Geräuschniveau im Einzugskanal und nach Außen auszeichnen. Der Wartungsdeckel ist leicht zu öffnen und er wird an das Gehäuse mit Scharnieren befestigt, deshalb ist der Ventilator leicht zu pflegen und zu reinigen. Nicht geeignet für die Beförderung von verschmutzter Luft, aggressiven, explosiven Gasen.

Laufgrad ist vorwärts gekrümmt, aus verzinktem Stahl.

Der Motor: Außenrotor, dauerhafte, keine Pflege erfordernde Lager.

Das Gehäuse: aus verzinktem Blech, aus Aluzinkblech.

Schallisoliation: Steinwolle, Steinwolle mit verstärkter Oberfläche, 50mm - 30mm dick, nicht entzündbar.



Acoustically insulated duct fans for round ducts. Maintenance cover is attached to the housing using fixed hinges and is easily opened, therefore the maintenance and cleaning of the fan is simple. Additional insulation of the fan box reduces noise level to the surroundings. Not suitable for polluted air, aggressive and explosive gases.

Impeller with forward curved blades made of galvanized steel.

Motor: external rotor, motor protection built-in thermal-contact, free-maintenance ball bearings.

Housing: with 30mm isolation made of galvanized steel, with 50mm isolation made of aluzinc steel.

Sound insulation: rock wool, 50 mm thickness.



Канальные акустические вентиляторы, отличаются низким уровнем шума в канале всасывания и окружающей среде. Обзорная крышка легко открывается и крепится к корпусу на шарнирах, поэтому вентилятору не требуется сложный уход, его легко чистить. Не используются при транспортировке загрязнённого воздуха, агрессивных, взрывоопасных газов.

Крыльчатка: загнутые вперёд лопатки, оцинкованная сталь.

Двигатель: наружный ротор, не требующие ухода подшипники с длительным сроком службы.

Корпус: оцинкованной жести, алуцинковой жести.

Звукоизоляция: минеральная вата, минеральная вата с усиленной поверхностью, толщиной 50 мм – 30 мм, негорючая.

#### Accessories



AP  
p. 185

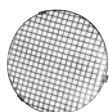

AGO  
p. 177



RSK  
SAT  
p. 167-168



AKS  
p. 160

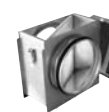

FD  
p. 152



FDI  
p. 153

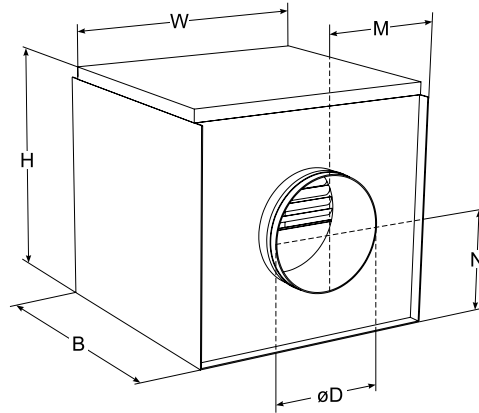

Type	Dimensions [mm]					
	B	W	H	M	N	øD
AKUp 125 M	392	400	300	150	151	125
AKUp 125 D	392	400	300	150	151	125
AKUp 160 M	392	400	300	170	151	160
AKUp 160 D	392	400	300	170	151	160
AKUk 200 M	444	444	420	222	250	200
AKUp 200 D	392	400	300	190	166	200
AKUp 250 D	694	694	420	268	220	250
AKUk 250 D	444	444	420	222	250	250
AKUp 315 M	694	694	420	236	234	315
AKUp 315 D	768	768	500	255	278	315
AKUp 400 D	768	768	500	295	268	400

## Accessories

 EKA  
p. 118

 AVS  
p. 126

 TGRV  
p. 143

 MTY  
p. 146

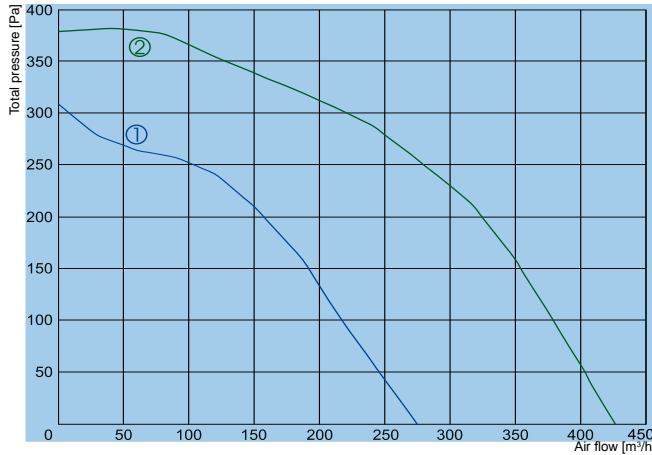

- ① — AKUp 125 M
- ② — AKUp 125 D

		AKUp 125 M	AKUp 125 D
Voltage/Frequency	[V/Hz]	230/50	230/50
Power consumption	[kW]	0,083	0,13
Current	[A]	0,37	0,57
Speed	[min <sup>-1</sup> ]	2200	1660
Max. airflow	[m <sup>3</sup> /h]	275	425
Max. air temperature	[°C]	70	45
Total sound pressure level at 1 m	[dBA]	35	38
Speed controller		TGRV1,5 / MTY0	TGRV1,5 / MTY1
Weight	[kg]	8,9	10
Wiring diagram		No. 2	No. 2
Protection class:	motor	IP-44	IP-44
	terminal box	IP-55	IP-55

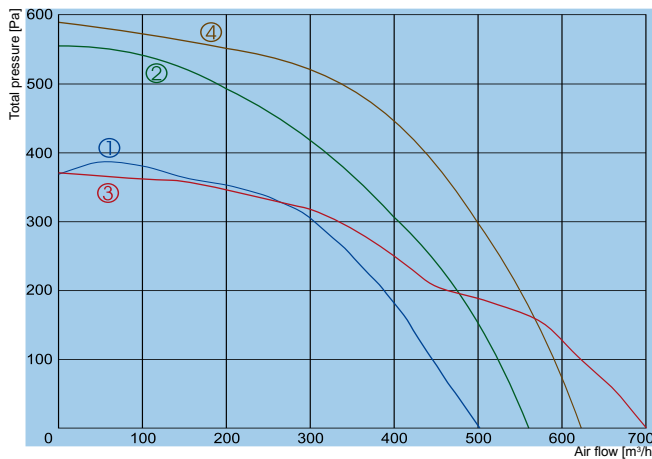

- ① — AKUp 160 M
- ② — AKUp 160 D
- ③ — AKUk 200 M
- ④ — AKUp 200 D

		AKUp 160 M	AKUp 160 D	AKUk 200 M	AKUp 200 D
Voltage/Frequency	[V/Hz]	230/50	230/50	230/50	230/50
Power consumption	[kW]	0,13	0,21	0,175	0,30
Current	[A]	0,57	0,92	0,77	1,30
Speed	[min <sup>-1</sup> ]	1660	1850	1700	2150
Max. airflow	[m <sup>3</sup> /h]	500	560	700	620
Max. air temperature	[°C]	45	40	40	40
Total sound pressure level at 1 m	[dBA]	38	41	40	46
Speed controller		TGRV1,5 / MTY1	TGRV1,5 / MTY1	TGRV1,5 / MTY1	TGRV2 / MTY2
Weight	[kg]	10	13	16	23
Wiring diagram		No. 2	No. 2	No. 2	No.2
Protection class:	motor	IP-44	IP-44	IP-44	IP-44
	terminal box	IP-55	IP-55	IP-55	IP-55

The fan characteristic curves were determined in accordance with DIN 24163 resp. ISO 5801. The sound power levels were determined in accordance with DIN 45635 resp. ISO 3744 at a distance of 1 m from the fan

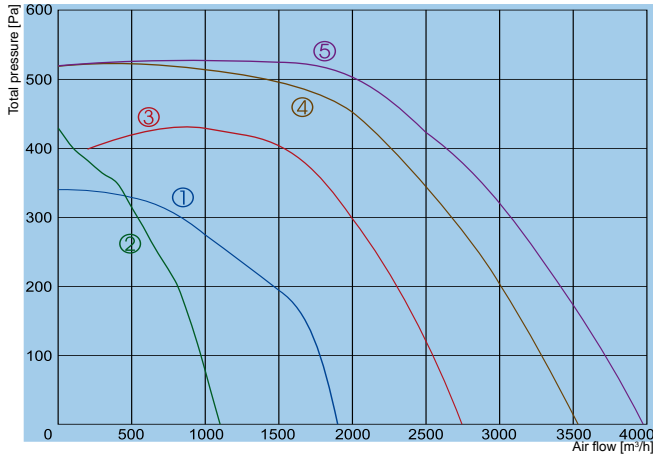

- ① — AKUp 250 D
- ② — AKUk 250 D
- ③ — AKUp 315 M
- ④ — AKUp 315 D
- ⑤ — AKUp 400 D

		AKUp 250 D	AKUk 250 D	AKUp 315 M	AKUp 315 D	AKUp 400 D
Voltage/Frequency	[V/Hz]	230/50	230/50	230/50	230/50	230/50
Power consumption	[kW]	0,69	0,28	1,15	2,5	2,5
Current	[A]	3,0	1,18	5,1	11,0	11,0
Speed	[min <sup>-1</sup> ]	1190	2790	1210	1340	1340
Max. airflow	[m³/h]	1800	1090	2750	3530	3970
Max. air temperature	[°C]	40	40	40	40	40
Total sound pressure level at 1 m	[dBA]	49	51	53	60	60
Speed controller		TGRV4/MTY4	TGRV1,2/MTY2	TGRV7	TGRV14	TGRV14
Weight	[kg]	41	40	54	59	61
Wiring diagram		No. 1	No. 2	No. 1	No. 1	No. 1
Protection class:	motor	IP-54	IP-44	IP-54	IP-54	IP-54
	terminal box	IP-55	IP-55	IP-55	IP-55	IP-55

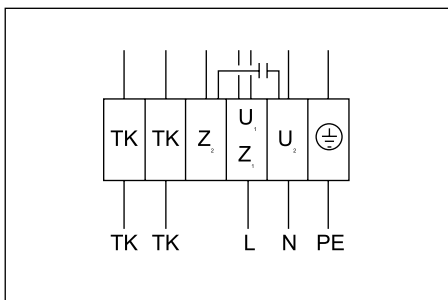

#### Wiring diagram No. 1 (1~230V)

- U<sub>1</sub> - brown
- U<sub>2</sub> - blue
- Z<sub>1</sub> - black
- Z<sub>2</sub> - orange
- TK - white
- PE - yellow-black

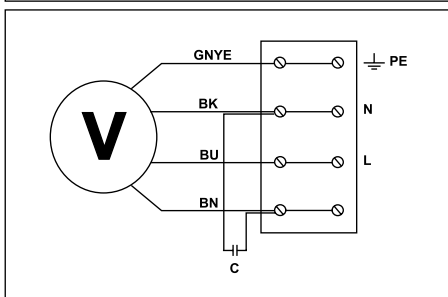

#### Wiring diagram No. 2 (1~230V)

- GNYE - green-yellow
- BK - black
- BU - blue
- BN - brown